

# Bachelor of Science in Engineering

(Major in General Engineering)

Sample Four-Year Plan for students starting in MATH 11 or higher

## 1 First-Year

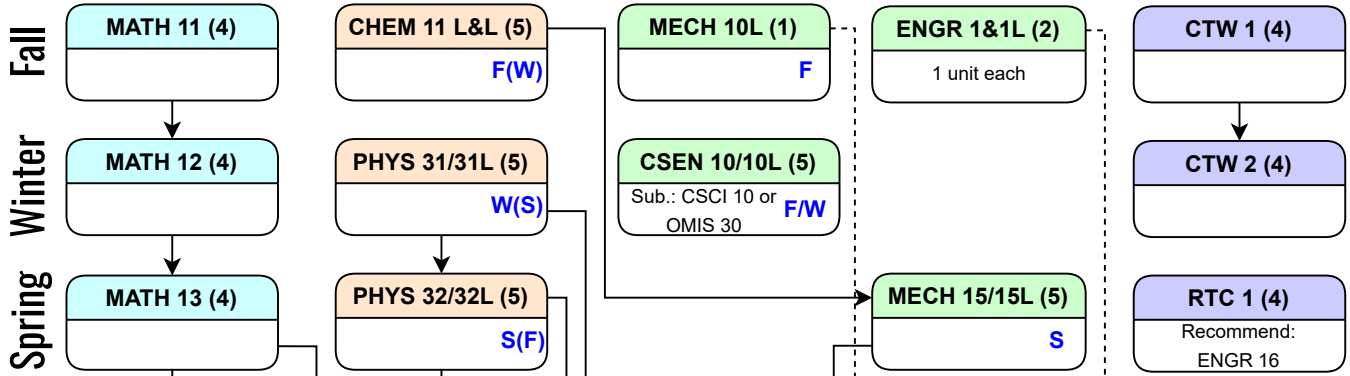

## 2 Sophomore

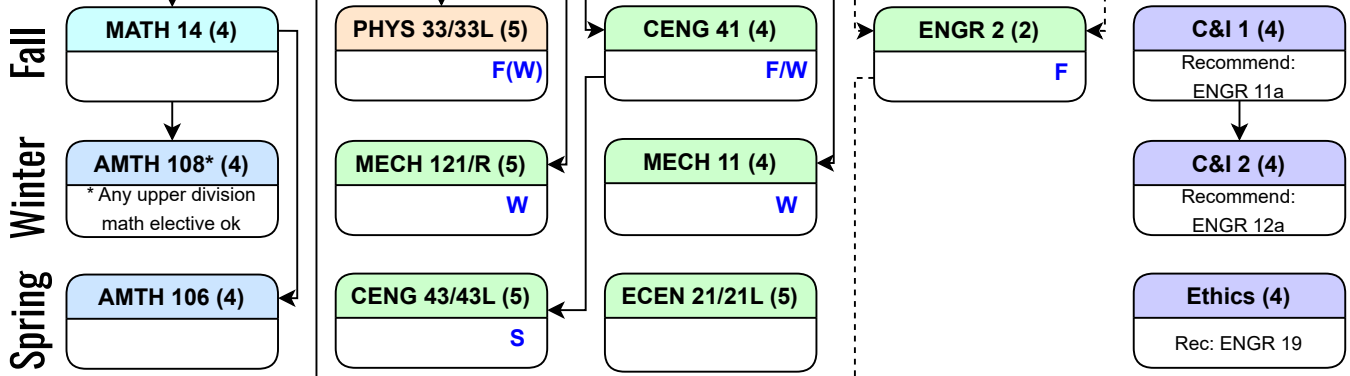

## 3 Junior

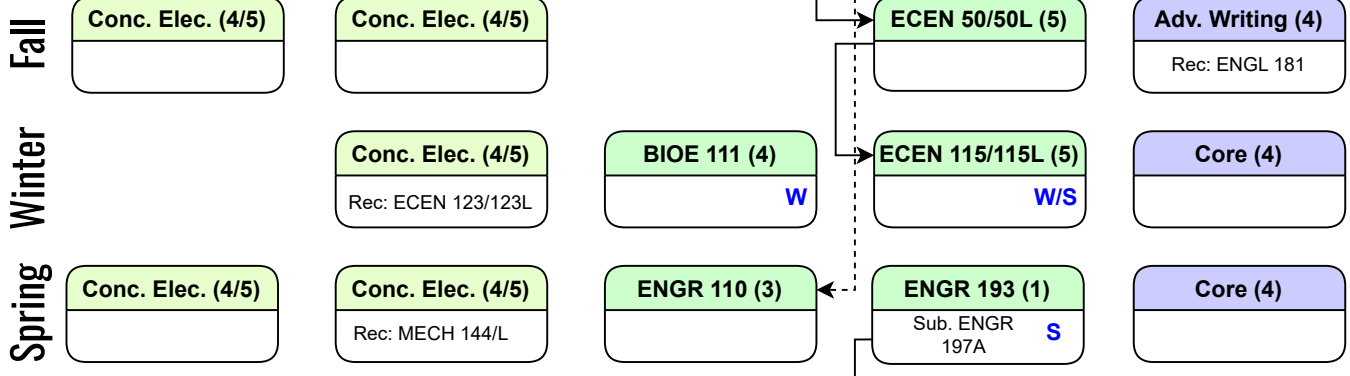

## 4 Senior

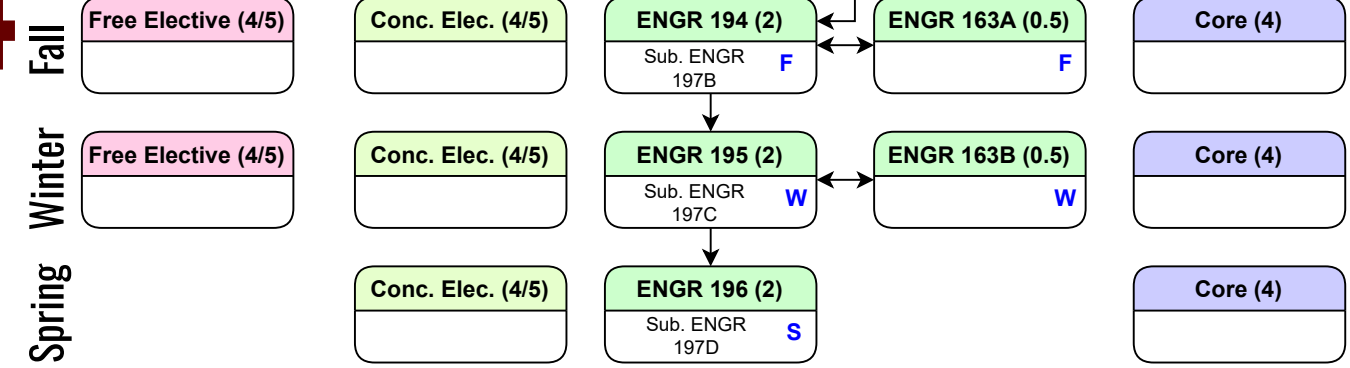

## Instructions and FAQs

- 1 Graduation requirements:** Students majoring in engineering must complete a minimum of 189 units, including the following:
- Senior Design - fulfilled through courses listed as Senior Design Project I, II & III [ENGR 194, 195, 196] + 1 unit seminar ENGR 163 (0.5 unit ENGR 163A + 0.5 unit ENGR 163B)
  - 36 upper division concentration units
    - Concentration electives must be approved by an advisor. Most but not all upper division engineering classes could be technical electives. Some recommendations for courses and when to take them are listed below.
  - \*AMTH 108 is the recommended upper division math elective, but another course may be substituted with approval from an advisor
  - ENGR 163A&B is a required seminar course for those graduating in General Engineering and is recommended if completing the Innovation, Design and Entrepreneurship Minor
  - Advanced writing ENGL 181 should be taken junior year
  - ENGR 110 is recommended sophomore or junior year and prior to senior design
  - ELEN 115/L is a recommended sophomore or junior year course for experience in application of electronic circuits
  - ELEN 123/L is a recommended junior year course for experience in systems integration
  - MECH 144/L is a recommended junior year course for experience in product design

- 2** Santa Clara University's **Core Curriculum** provides a humanistic education that leads toward an informed, ethical engagement with the world. The Core Curriculum consists of three phases of academic work: Foundations, Explorations, and Integrations. For more information go to: [www.scu.edu/provost/core](http://www.scu.edu/provost/core)

Core requirements needing to be fulfilled beyond the General Engineering degree include:

- Cultures and Ideas 3
- Social Science
- Diversity
- Religion, Theology, and Culture 2 & 3
- Experiential Learning for Social Justice
- \*\*Listed courses for RTC1 (ENGR 16) and Ethics (ENGR 19) are part of plan, but may be substituted with any core course that fulfills the core requirement

Note that as an engineering student you may 'double dip' in core courses. The list of double dip courses is here (<https://www.scu.edu/media/school-of-engineering/pdfs/current-student-resources/undergraduate/Useful-Double-Dips-9.20.21.pdf>) or you can search via Workday with an advanced search.

- 3 Pathways** provide students an additional opportunity to make intentional and reflective choices about their own education as they study a theme or topic from a number of disciplinary perspectives and identify connections and relationships among ideas.

Students should make reflective and intentional choices to study a theme from multiple disciplinary or methodological perspectives and to perceive connections. Engineering students need to take 3 pathway courses (no more than 2 of them engineering). For more information go to:

<https://www.scu.edu/provost/core/pathways/>

- 4 Study abroad** can be accomplished by taking engineering classes abroad to fulfill requirements. These classes must be approved by your advisor PRIOR to leaving for the study abroad term. Note that the Study Abroad office will require a four-year plan as part of the application process. More information can be found here: <https://www.scu.edu/globalengagement/study-abroad/>